

Basic Characteristics Data

Model	Circuit method	Switching frequency [kHz]	Input current [A]	Rated input fuse	Inrush current protection	PCB/Pattern			Series/Parallel operation availability	
						Material	Single sided	Double sided	Series operation	Parallel operation
DAS50F	Forward converter	500	0.5 *1	-	-	Aluminum	Yes		Yes	*3
DAS5048	Forward converter	500	1.3 *2	-	-	Aluminum	Yes		Yes	*3
DAS100F	Forward converter	500	1.0 *1	-	-	Aluminum	Yes		Yes	Yes
DAS10048	Forward converter	500	2.6 *2	-	-	Aluminum	Yes		Yes	Yes

*1 The value of input current is at DCIN130V and rated load.

*2 The value of input current is at DCIN48V and rated load.

*3 Refer to Instruction Manual

1	Pin Connection	DAS-8
2	Function	DAS-8
	2.1 Overcurrent protection	DAS-8
	2.2 Overvoltage protection	DAS-8
	2.3 Adjustable voltage range	DAS-8
	2.4 Remote ON/OFF	DAS-9
	2.5 Remote sensing	DAS-9
	2.6 Isolation	DAS-9
	2.7 Thermal protection	DAS-9
3	Wiring to Input/Output Pin	DAS-9
4	Series and Parallel Operation	DAS-10
	4.1 Series operation	DAS-10
	4.2 Parallel operation	DAS-10
5	Implementation · Mounting Method	DAS-11
	5.1 Mounting method	DAS-11
	5.2 Derating	DAS-12
6	Input Voltage/Current Range	DAS-12
7	Cleaning	DAS-12
8	Input/Output Pin	DAS-12
9	External Fuse	DAS-12
10	Thermal Design	DAS-12
11	Design of the Input Rectification Filtering Circuit	DAS-13
12	Noise Filter Design	DAS-15
13	Option Parts	DAS-16
	13.1 Heat sink	DAS-16

1 Pin Connection

Table 1.1 Pin connection and function

No.	Pin Connection	Function
①	+DC INPUT	+DC(+V) input
②	+DC INPUT	+DC(+V) input
③	-DC INPUT	-DC(-V) input
④	RC	Remote ON/OFF
⑤	TRM	Adjustment of output voltage
⑥	+S	+Remote sensing
⑦	+V DC OUTPUT	+DC(+V) output
⑧	+V DC OUTPUT	+DC(+V) output
⑨	-V DC OUTPUT	-DC(-V) output
⑩	-V DC OUTPUT	-DC(-V) output
⑪	-S	-Remote sensing
⑫	CB(NC)	Current balance (This function is not built-in in DAS50. No contact internally, but normally it should be connected to -V output pin.)
—	FG	Frame ground

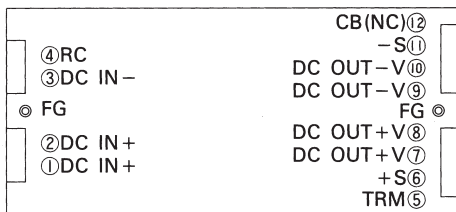

Fig.1.1 Pin connection(bottom view)

* The pin in () is for DAS50.

2 Function

2.1 Overcurrent protection

Overcurrent protection is built-in and comes into effect at over 105% of the rated current. Overcurrent protection prevents the unit from short circuit and overcurrent condition. The unit automatically recovers when the fault condition is cleared.

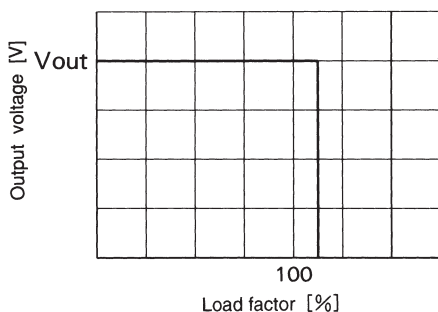

Fig.2.1 Overcurrent protection characteristics

2.2 Overvoltage protection

- The overvoltage protection circuit is built-in and comes into effect at 115 - 140% of the rated voltage. The DC input should be shut down if overvoltage protection is in operation. The minimum interval of DC recycling for recovery is for 2 to 3 minutes(*).
- * The recovery time varies depending on input voltage.

Remarks:

Please note that the unit's internal components may be damaged if excessive voltage(over rated voltage)is applied to output terminal of power supply. This could happen when the customer tests the overvoltage performance of the unit.

2.3 Adjustable voltage range

- The output voltage is adjustable by external potentiometer.
- When the output voltage adjustment is not used, open the TRM pin. Also connect the +S pin to +V output, and -S pin to -V output, respectively.
- When the output voltage adjustment is used, note that the overvoltage protection circuit operates when the output voltage sets too high.
- Output voltage is increased by turning potentiometer clockwise and is decreased by turning potentiometer counterclockwise.
- The wiring to the potentiometer should be as short as possible and it must come from the remote sensing pins(+S and -S).

The temperature coefficient becomes worse and it depends on the type of resistor and potentiometer, below devices outside the power supply are recommended.

- Resistor ----- Metal film type, coefficient of less than $\pm 100\text{ppm}/^\circ\text{C}$.
- Potentiometer--- Cermet type, coefficient of less than $\pm 300\text{ppm}/^\circ\text{C}$.

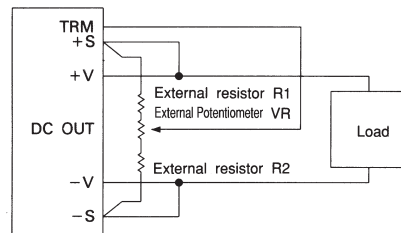

Fig.2.2 Connection devices outside the power supply

Table 2.1 Devices outside the power supply

No.	Output voltage	The constant value of device outside the power supply. [Ω]					
		DAS50			DAS100		
		VR	R1	R2	VR	R1	R2
1	5V	1K	0	0	1K	110	180
2	12V	1K	820	0	2K	2.4K	240
3	24V	1K	2.4K	0	5K	11K	390

0 Ω means to be shorted.

2.4 Remote ON/OFF

■The ground terminal of remote ON/OFF circuit is connected with -V input terminal.

Between RC and -V input: Output voltage is ON at "Low" level or short circuit(0 - 1.2V).

Between RC and -V input: Output voltage is OFF at "High" level or open circuit(2.4 - 5.5V).

(Connection example)

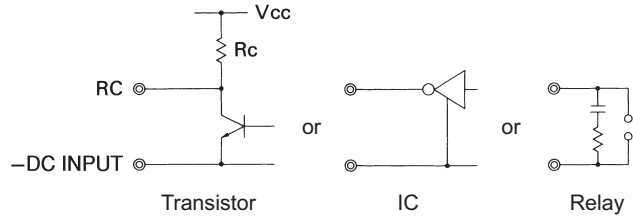

When RC terminal is "Low" level, fan out current is 1mA typ.
When Vcc is applied, use $5V \leq V_{cc} \leq 24V$. When remote ON/OFF function is not used, please short between RC and -V input.

2.5 Remote sensing

■When not using remote this function, confirm that terminals are shorted between +S and +V output, and between -S and -V output.

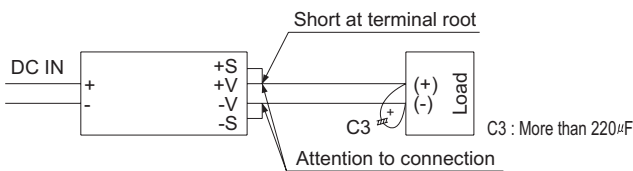

Fig.2.3 Connection when not using remote sensing

- Devices inside the power supply might be damaged when poor connection on load lines occurs, e. g. because of loose connector screws.
- Thick wire should be used for wiring between power supply and load, and line voltage drop should be less than 0.3V.
- When using this function, install capacitors with more than 220µF for C1, C2 and C3. These will prevent the output voltage from becoming unstable due to the long wires to the load or some type of load connected.
- Twisted-pair wire or shield wire should be used for sensing wire.
- Please do not draw output current from +S, -S terminal.

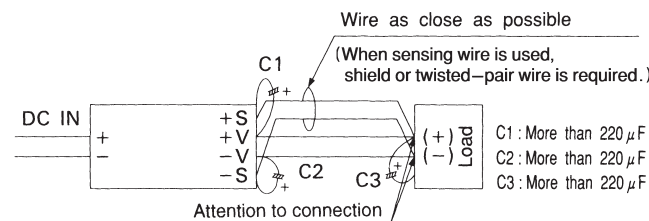

Fig.2.4 Connection when using remote sensing

2.6 Isolation

■For a receiving inspection, such as Hi-Pot test, gradually increase(decrease)the voltage for the start(shut down). Avoid using Hi-Pot tester with the timer because it may generate voltage a few times higher than the applied voltage, at ON/OFF of a timer.

2.7 Thermal protection

■Thermal protection is built-in. If this function comes into effect, shut down the output, eliminate all possible causes of overheating, and drop the temperature to normal level. Output voltage recovers after applying input voltage. To prevent the unit from overheating, avoid using the unit in a dusty, poorly ventilated environment.

3 Wiring to Input/Output Pin

- When the line impedance is high or the input voltage rises quickly at start-up(less than 10µs), install a capacitor(Cin) with more than 2.2µF between +V and -V input pins(within 5cm from the pins).
- Refer to Fig.3.1 for recommended values of the noise filter for the input rectification filtering circuit. When the distance between the power supply(DAS) and the primary decoupling capacitor is more than 20cm, install a common mode choke(Lin) with more than 400µH between the unit and input rectification filtering circuit.
- When the total of the primary decoupling capacitor is more than 4,400pF, the value defined in the specification may not be satisfied at the Hi-Pot test between input and output. In this case, it is recommended to install a capacitor(Cy) between output and the ground. The leakage current will increase as the primary decoupling capacitor increases, therefore, consider the circuit for the safety standards when designing.
- Maximum current per a pin is 10A, and when output current exceeds 10A, two pins are required.
- When the load is light(e.g. the load factor is about 5%), the output voltage may be unstable. In this case, install a capacitor(C3) whether the remote sensing is used or not(Refer to Fig.2.3 and 2.4).

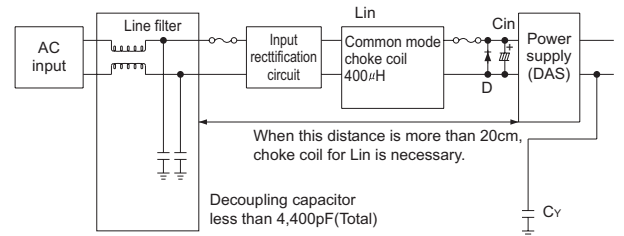

Fig.3.1 Connection of input circuit

Reverse input voltage protection

■ Avoid the reverse polarity input voltage. It will damage the power supply.

It is possible to protect the unit from the reverse input voltage by installing an external diode as shown in Fig.3.2.

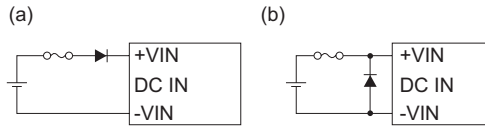

Fig.3.2 Reverse input voltage protection

4 Series and Parallel Operation

4.1 Series operation

■ Series operation is available by connecting the outputs of two or more power supplies, as shown below. Output current in series connection should be lower than the lowest rated current in each unit.

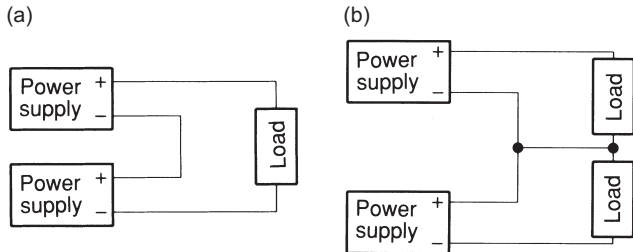

Fig.4.1 Examples of series operation

4.2 Parallel operation

● **DAS50**

- Parallel operation is not possible.
 - Redundancy operation is available by wiring as shown below.
 - Even a slight difference in output voltage can affect the balance between the values of I1 and I2.
- Please make sure that the value of I3 does not exceed the rated current of a power supply.

$$I_3 \leq \text{the rated current value}$$

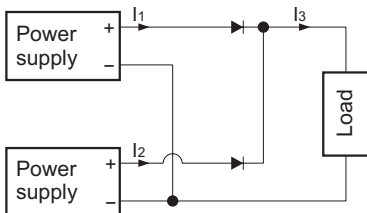

Fig. 4.2 Examples of redundancy

● **DAS100**

- Parallel operation is available by connecting the units as shown below.
- As variance of output current drew from each power supply is maximum 10%, the total output current must not exceed the value determined by the following equation.

$$\begin{aligned} & \text{(output current in parallel operation)} \\ & = (\text{the rated current per unit}) \times (\text{number of unit}) \times 0.9 \end{aligned}$$

When the number of units in parallel operation increases, input current increases at the same time.

Adequate wiring design for input circuitry is required, such as circuit pattern, wiring and current capacity for equipment.

- In parallel operation, the maximum operative number of units is 5.
- In parallel operation, please connect diode to the + side of the output circuit. If diode is connected to the - side, it will damage the unit or/and, the balancing function will not work.
- When the unit is not operated in parallel, open the CB pin.
- When remote sensing is used in parallel operation, the sensing wire must be connected only to the master. Terminals between +S & +V and -S & -V of "slave" power supplies must be shorted.
- When the aluminum base plate temperatures are different among the units in parallel, the output voltage regulation will not balance. So that design the cooling which the temperatures will be kept equal for all units(e.g. mounting on the same heat sink).

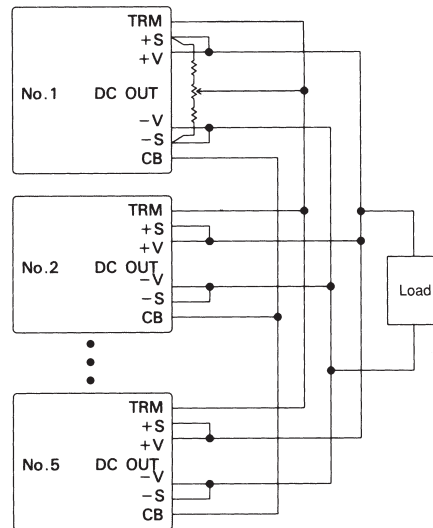

Fig.4.3 Examples of parallel operation

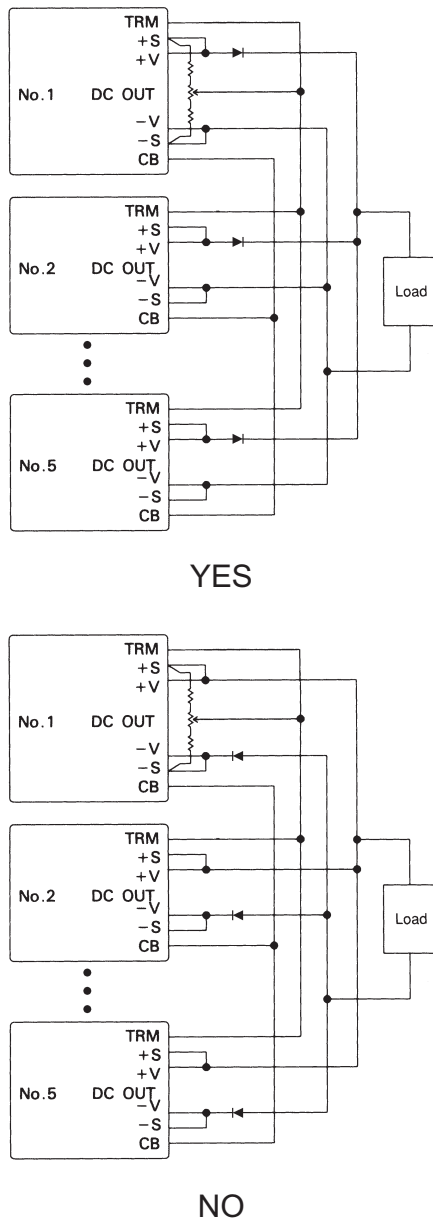

Fig.4.4 When connected Diode at output circuit for parallel operation

★ When the output voltage adjustment is not used, open the external resistance and potentiometer.

5 Implementation - Mounting Method

5.1 Mounting method

- The unit can be mounted in any direction. When two or more power supplies are used side by side, position them with proper intervals to allow enough air ventilation. Aluminum base plate temperature around each power supply should not exceed the temperature range shown in derating curve.
- Avoid placing the DC input line pattern lay out underneath the unit it will increase the line conducted noise. Make sure to leave an ample distance between the line pattern lay out and the unit. Also, avoid placing the DC output line pattern underneath the unit because it may increase the output noise. Lay out the pattern away from the unit.

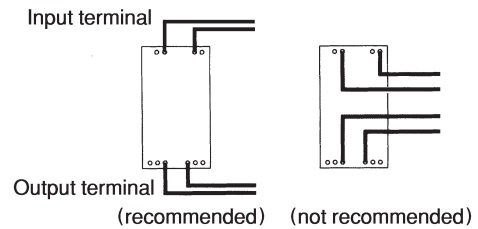

Fig.5.1 Pattern lay out

- High-frequency noise radiates directly from the unit to the atmosphere. Therefore, design the shield pattern on the printed circuit board and connect its one end to FG. The shield pattern prevents noise radiation.

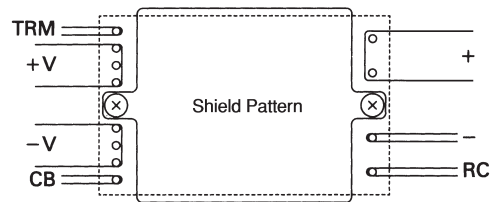

Fig.5.2 Shield pattern lay out(bottom view)

- Keep the distance between the input line filter and the unit as far as possible. When they are too close, the line conducted noise will increase because the radiation noise is propagated into the filter.
- When a long wire is used between the input line filter and the unit, the conducted noise voltage may increase due to the resonance of the wiring and the decoupling capacitor. Install a common mode choke(0.4mH - 2mH for each power supply) near the unit. Make sure to connect the capacitor with more than 2.2μF to the input pins of the unit.

5.2 Derating

- Use with the conduction cooling (e.g. heat radiation by conduction from the aluminum base plate to the attached heat sink). Fig.5.3 shows the derating curve in terms of the aluminum base plate temperature. In the hatched area, the specification of Ripple, Ripple Noise is different on other area.

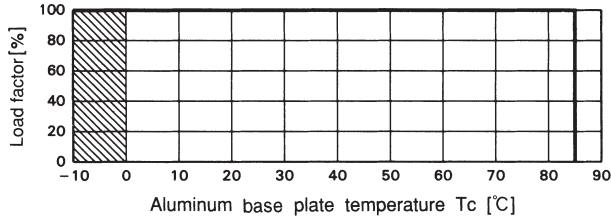

Fig.5.3 Derating curve

6 Input Voltage/ Current Range

- When a non-regulated source is used as a front end, make sure that the voltage fluctuation together with the ripple voltage will not exceed the input voltage range.
- Use an input power supply unit with enough power, considering the start-up current (I_p) for the DC-DC.

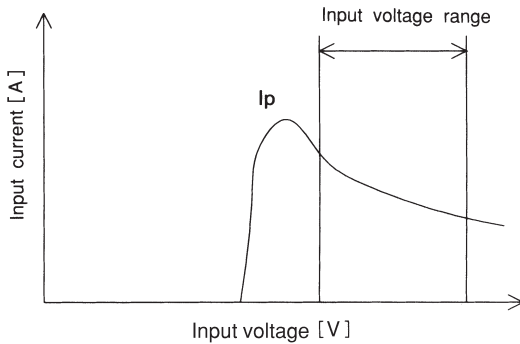

Fig.6.1 Input current characteristics

7 Cleaning

- Clean the product with a brush. Prevent liquid from getting into the product.
Do not soak the product into liquid.
- Do not stick solvent to a name plate or a resin case.
(If solvent sticks to a name plate or a resin case, it will cause to change the color of the case or to fade letters on name plate away.)
- After cleaning, dry them enough.

8 Input/Output Pin

- When too much stress is applied on the input/output pins of the unit, the internal connection may be weakened. As below in Fig. 8.1, avoid applying stress of more than 29.4N(3kgf) on the pins horizontally and/or vertically.
- The input/output pins are soldered on PCB internally, therefore, do not pull or bend them with abnormal forces.
- When additional stress is expected to be put on the input/output pins because of vibration or impacts, fix the unit on PCB (using silicone rubber or fixing fittings) to reduce the stress onto the input/output pins.

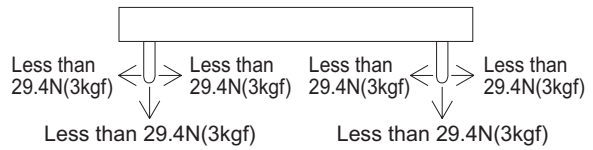

Fig.8.1 Stress onto the pin

9 External Fuse

- Fuse is not built-in at input side. In order to protect the unit, use the normal-blow or slow-blow type fuse at input.
- When the input voltage is supplied to more than one units from a single input rectification filtering circuit, install a regular or slow-blow type fuse to each unit between DC Input and +DC INPUT pin.

Table 9.1 The rated current of fuse (Normal-blow or slow-blow type)

Model	DAS5048	DAS10048	DAS50F	DAS100F
Rated current	5A	6A	2A	3A

10 Thermal Design

- The unit relies on the aluminum base plate to transfer the inner losses by conduction cooling to free air. The aluminum base plate temperature must be kept below 85°C and therefore the unit requires the thermal design just as the power semiconductor does.

(1) Fig.10.1 shows the recommended value to use for the thermal resistance of the heat sink in terms of the temperature. It is calculated based on the required output wattage. These values show the thermal resistance of the heat sink with the aluminum base plate temperature at 85°C, in order to obtain maximum reliability, keep the aluminum base plate temperature low.

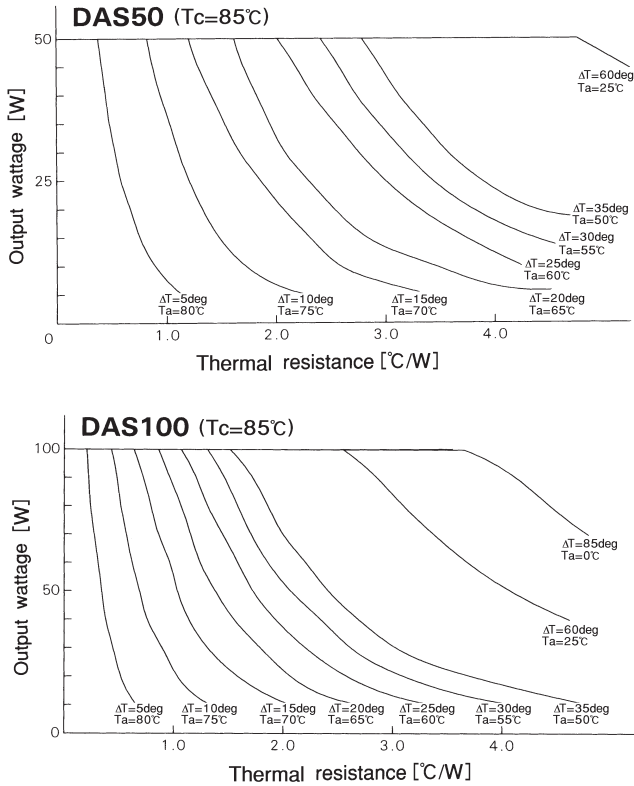

Fig.10.1 Output wattage and the thermal resistance of the heat sink

● Design examples

① Finding out the thermal resistance of the heat sink.

Assumption: The aluminum base plate temperature(T_c) is 85°C.

The ambient temperature(T_a) is 65°C.

$\Delta T = T_c - T_a = 85 - 65 = 20$ deg

The maximum output wattage to deliver is 60W.

Reading the value at point A in Fig.10.2, it is 1.25(°C/W).

② Finding out the ambient temperature for a given thermal resistance.

Assumption: The aluminum base plate temperature(T_c) is 85°C.

The thermal resistance of the heat sink is 2.0(°C/W).

The output wattage to deliver is 40W.

Reading the value at point B in Fig.10.2, it is $\Delta T = 25$ deg.

$T_a = T_c - \Delta T = 85 - 25 = 60$ °C

③ Finding out the thermal resistance of the heat sink.

Assumption: The aluminum base plate temperature(T_c) is 75°C.

The ambient temperature(T_a) is 65°C.

$\Delta T = T_c - T_a = 75 - 65 = 10$ deg

Maximum output wattage to deliver is 60W.

Reading the value at point C in Fig.10.2, it is 0.6(°C/W).

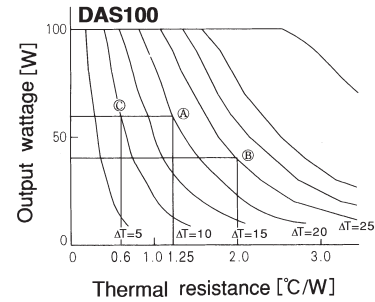

Fig.10.2 Design examples

- (2) The thermal resistance of the heat sink varies depending on the operating condition. It is, for example, affected by the condition of air convection around the heat sink when used under convection cooling, and by the air flow of the fan when used under the forced air cooling. By using the selected heat sink, make sure that the base plate temperature is below the designed level.
- (3) Apply the silicone grease at the junction to reduce the thermal resistance.
- (4) Optional heat sinks are available. Refer to "Section 13 Option Parts" for details.

11 Design of the Input Rectification Filtering Circuit

■ The rectification filtering circuit is required when the unit is used with AC input. DAS50F and 100F have a wide input range(DC88V to 370V).

Fig.11.1 shows the circuit with a wide range. Fig.11.2 shows the circuit with user selectable input voltage.

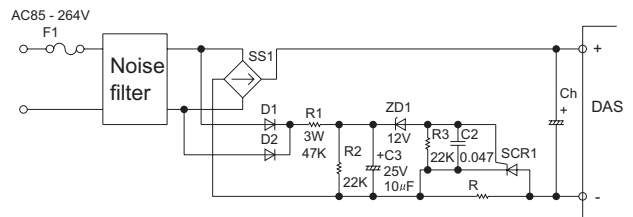

SCR1 is the low gate trigger current thyristor.

(Ex. SF5J42; "TOSHIBA")
 $I_{GT} = 200 \mu A (MAX)$

Fig.11.1 Example of circuit with wide range

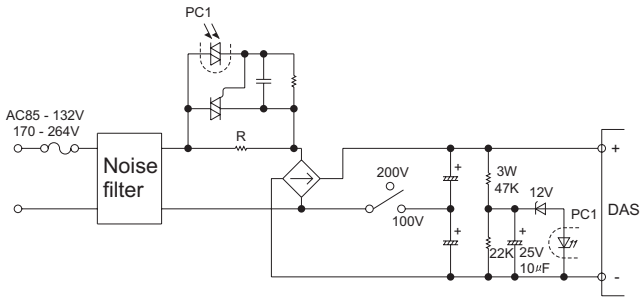

PC1 is the extra low trigger current opto coupler.
 (Ex. TLP668J; "TOSHIBA")
 $I_{FT}=3mA(MAX)$

Fig.11.2 Example of circuit with user selectable input voltage

Referring to Fig.11.1, item (1) to (5) below show some design examples of key components.

(1)Input fuse

For the protection of the unit, install either an input circuit breaker or a fuse. When selecting these parts, consider the steady-state current and the inrush current. Install a normal-blow or slow-blow type fuse.

(2)Noise filter

In order to reduce the conducted noise from the unit to the AC line and to increase the immunity level against the external noises, a noise filter should be installed. Refer to "Section 12 Noise Filter Design" for details.

(3)Rectification circuit(Diode bridge)

It rectifies the AC input to DC. The rated voltage is 600V and the rated current is as follows.

50W	(DAS50)	: 3A to 4A
100W	(DAS100)	: 4A to 5A
150W	(DAS50+DAS100)	: 5A to 10A
200W	(DAS100 x 2)	: 10A to 15A

(4)Inrush current limiting

This rectification filtering circuit employs a capacitor input type. When input voltage is applied, an inrush current will flow to charge the capacitor. To avoid the damage, an inrush current limiting is required. The circuit allows to charge the capacitor through the current limiting resistance R when applying the input, and will be shorted upon completion of the charging by the thyristor.

$$\text{Inrush current(at AC200V)} = \frac{200 \times \sqrt{2}}{R}$$

- ★ The inrush current limiting will not be activated when the input is applied again without allowing a long enough interval.
- ★ Select a thyristor with the same current rating as the input rectifier.
- ★ The thyristor trigger delay time is set to 100ms for the circuit constants in Fig.11.1 and 11.2. These constants must be appropriately designed depending on the capacity of the electrolytic capacitor and the inrush current.

(5)Filtering circuit(Filtering capacitor)

The selection of the filtering capacitor depends on the output hold-up time and the ripple current flowing in the capacitor.

i) Obtain the capacitance(Ch) from the output hold-up time as follows.

$$Ch = \frac{2 \times Po \times Th}{(V1^2 - V2^2) \times \eta}$$

- Ch : Capacity of the filtering capacitor
- Po : Output wattage
- Th : Hold-up time
- V1 : Input voltage $100 \times \sqrt{2}$
- V2 : Minimum input voltage of the unit
- η : Efficiency

Calculation example

Assumptions

- ① DAS100F is used with a wide input.
- ② The hold-up time is 20ms at AC 100V.
- ③ The efficiency of DAS100F is 80%.

$$Ch = \frac{2 \times 100W \times (20ms+5ms^*)}{((141V)^2 - (88V)^2) \times 0.8} = 515\mu F$$

- ★ 5ms in the formula above is added considering the ripple voltage of the filtering capacitor.

ii) Obtain the ripple current for selection of the capacitor as follows.

Calculation example

$$\text{Ripple current} = \frac{2.5 \times Po}{VIN} = \frac{2.5 \times 100W}{100V} = 2.5A$$

- ★ The unit has a built-in normal mode filter effective to reduce the high frequency (switching frequency) ripple current.
- ★ Select a capacitor which meets both the capacity and the ripple current requirements.

- * The filtering capacitor is one of the critical parts which determine the reliability of the power supply system and its life time becomes shorter as the ambient temperature becomes higher. Take special consideration on the lay out of the parts around the capacitor which intimately linked to long-time reliability.
- * The rated voltage for the filtering capacitor is determined in terms of the input voltage as below.

AC 100V type: more than DC 200V
 AC 200V type: more than DC 400V

12 Noise Filter Design

Overview of the noise

Various noises will come into the unit from the AC lines. The switch mode power supply will also generate the conducted noise to the AC lines. The noise filter to be installed with the unit aims at reducing both types of noises. Descriptions below explain the filter to reduce the noise level from the unit to the AC lines.

(1) Common mode noise and differential mode noise

- The conducted noise feedback can be categorized into two. That is,
- Differential mode noise which exists between the AC lines
 - Common mode noise which exists between the AC lines and FG

The line filters must be designed for these two separately. Fig.12.1 and 12.2 show the overview of the paths of the common mode noise and the normal differential noise.

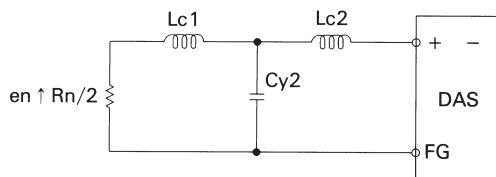

Fig.12.1 Common mode noise path

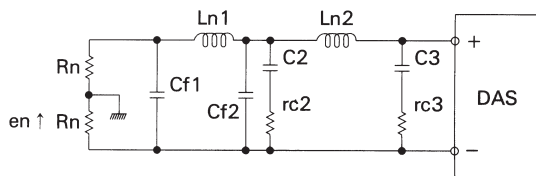

Fig.12.2 Differential mode noise path

(2) Noise filter design

Design the filters for the differential mode noise and the common mode noise separately. Some key points in the design are described below.

- * The design of the circuits and constants here are assuming the ideal parts lay out, provided that no stray capacity, wiring inductance and leakage flux exist. Therefore, the measurement is requested on the final product.

① Differential mode noise

As shown in Fig.12.2, the differential mode noise from the input pin of the unit should be reduced using a low-pass filter as follows: (C3, rc3) → (Ln2, C2, rc2, Cf2) → (Ln1, Cf1). As for the noise level, measure the voltage at Rn. Therefore, the noise filter should be designed based on the input noise current as the source of the noise. Accordingly, Table 12.1 shows the recommended constants for the line filters.

- * Table 12.1 shows the typical ESR(rc) values of the filtering capacitor. For actual selection, contact the capacitor manufacturer or measure the actual value.
- * Ln1 and Ln2 show the value of the filter coil leakage inductance. Usually these values are not listed in the catalogs. To make an appropriate selection, contact the filter coil manufacturer or measure the actual value.
- * When more than one units(n) are connected to a single line filter, set the rc value to 1/n, or fp1(resonance frequency of the noise filter) to $1/\sqrt{n}$ in order to obtain the same amount of noise reduction.

$$[fp1 = 1/2\pi \sqrt{(Ln1 \cdot Cf1)}]$$

Table 12.1 Recommended constants for line filter

No.	Parts	EMI level		Remarks
		FCC-A	FCC-B	
1	C3 *1	—	2.2μF or above	
2	rc3 *1	—	—	ESR of C3
3	Ln2	—	20μH or above	
4	C2	680μF or above	680μF or above	Filtering capacitor(Ref. Section 11)
5	rc2	0.3Ω	0.3Ω	ESR of the filtering capacitor
6	Ln1	80μH or above	80μH or above	
7	Cf1	0.22μF or above	0.47μF or above	
8	Cf2	0.022μF or above	0.022μF or above	

- *1: C3 and rc3 have almost no effect on the noise level. However, it is the capacitor that reduces an increase of impedance by the cascade installation of the noise filter to meet the FCC-B.

② Common mode noise

As shown in Fig.12.1, the common mode noise should be reduced by decreasing the noise voltage between the +/- DC input pins and FG using a low-pass filter as follows: (Lc2, Cy2) → (Lc1, Rn). As for the noise level, measure the voltage at Rn. Therefore, the noise filter should be designed based on the input noise voltage as the source of the noise. Accordingly, Table 12.2 shows the recommended constants for line filters.

- ★ When more than one units (n) are connected to a single line filter, multiply the Cy2 value or Lc1 value by (n) in order to obtain the same amount of noise reduction. Note that the leakage current will increase as the Cy2 value increases.
- ★ Use the filter coil with small stray capacity in order to obtain the noise reduction at the high frequency band.

Table 12.2 Recommended constants for line filter

No.	Parts	EMI level		Remarks
		FCC-A	FCC-B	
1	Lc2	—	1mH	
2	Cy2	4400pF	4400pF	
3	Lc1	10mH	4mH	

13 Option Parts

13.1 Heat sink

(1)Table 13.1 shows the available heat sinks.

Table 13.1 Available types of heat sink

No.	Heat sink model		External dimension [mm]			Thermal resistance [°C/W]		Appearance
			H	W	D	Convection cooling	Forced air cooling	
1	50W	F-DA50A	12	57.5	114.5	11.3	Refer to Fig.13.1	Vertical type
2		F-DA50B				9.3		Horizontal type
3		F-DA50C	30			3.8	Refer to Fig.13.2	Vertical type
4		F-DA50D				3.6		Horizontal type
5	100W	F-DA100A	12	129.5	10.9	Refer to Fig.13.3	Vertical type	
6		F-DA100B			8.3		Horizontal type	
7		F-DA100C	30		3.6	Refer to Fig.13.4	Vertical type	
8		F-DA100D			3.2		Horizontal type	

Vertical type

Horizontal type

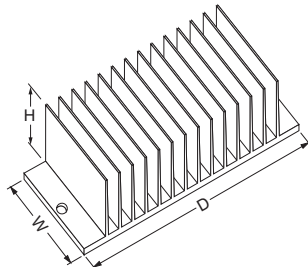
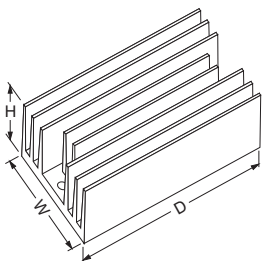

(2)Fig.13.1, 13.2, 13.3 and 13.4 show the thermal resistance when the forced air cooling is used.

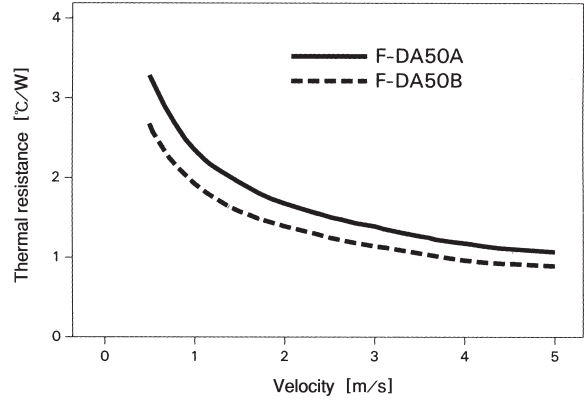

Fig.13.1 Thermal resistance of heat sink for 50W(Forced air)

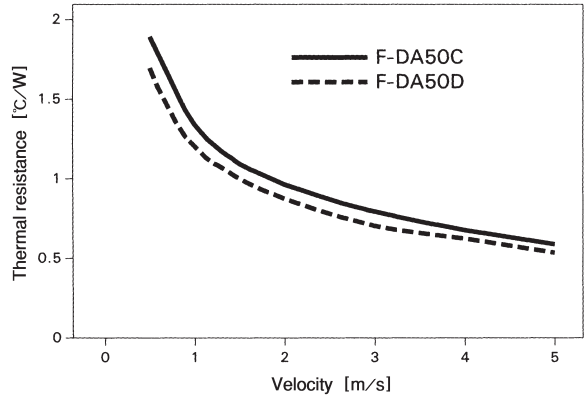

Fig.13.2 Thermal resistance of heat sink for 50W(Forced air)

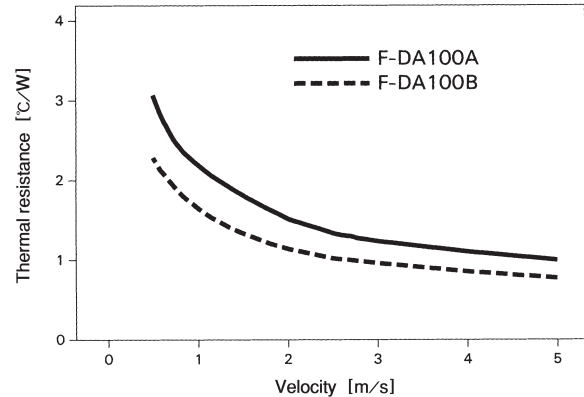

Fig.13.3 Thermal resistance of heat sink for 100W(Forced air)

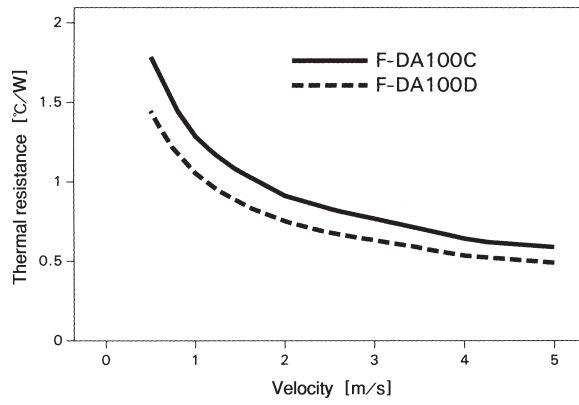

Fig.13.4 Thermal resistance of heat sink for 100W(Forced air)